

**Digital Undercounter
 ecostore HP Premium Refrigerated
 Counter - 290lt, 2-Door on wheels and
 with UK plug**

ITEM # _____

MODEL # _____

NAME # _____

SIS # _____

AIA # _____

712691 (EHR2BLS)

2-door refrigerated counter, saladette with cut-out for containers, -2+10°C, 290lt, AISI 304

Short Form Specification

Item No. _____

External and internal in AISI 304 stainless steel, galvanized back panel. Worktop thickness 50mm, fitted with cut-out for n. 3 GN 1/3 containers (not included) and stainless steel lid. Insulation thickness 90mm. N. 2 full doors. Built-in refrigeration unit. Ventilated operating mode. Evaporator. Electronic microprocessor control with external digital temperature display. Automatic defrost. Operating temperature: -2+10°C. CFC and HCFC free. R290 gas in refrigeration circuit. Gas in foam: Cyclopentane. Supplied with n. 2X1/1GN rilsan coated grids and n. 4 sets of 2 stainless steel grid runners with 15 adjustable positions.

Main Features

- Self closing stainless steel doors (< 90°).
- Internal structure with numerous charging positions available to host grids, ensuring higher net capacity and a greater storage space.
- Preservation performances and temperature uniformity within the cell guaranteed at 5-HEAVY DUTY (40°C) working conditions according to EN16825:2016 test protocol.
- Certified safety CE requirements.
- Frontal and easy access to all components in the cooling unit.
- Fully removable cooling unit to facilitate maintenance.
- Combination of doors and drawers to suit any configuration need, with the possibility to change the configuration on site. Right cooling unit available on request.
- Hot gas automatic evaporation of defrost water.
- 0mm clearance installation space: tower configuration cooling unit guarantee performance with frontal ventilation only; this unique solution allows installation against the wall or side by side with other appliances, even on the cooling unit side to maximize the use of kitchen space.
- Prearranged to fit RS485 port to facilitate connection to a remote computer and integrated HACCP systems.
- Fully compliant HACCP digital control: when temperature exceeds critical limits, acoustic and visual alarms are activated. Up to two months of event are kept in memory.
- Large digital white-digit display with humidity selection button (3 preset level), internal temperature display and setting, manual activation of defrost cycle and turbo frost cycle (to rapidly cool warm loads).
- Raised rear upstand permits unit to be connected up against the wall for better hygiene.
- Anti-tilt runners accept GN 1/1 containers.
- Adjustable temperature range from -2 °C to +10 °C to suit meat, fish and dairy storage requirements.
- Connectivity ready for real time access to connected appliances from remote and data monitoring (requires optional accessory).
- [NOT TRANSLATED]
- [NOT TRANSLATED]

APPROVAL: _____

Construction

- Built-in compressor to suit operating conditions.
- Developed and produced in ISO 9001 and ISO 14001 certified factory.
- Fault code display.
- Interior base with rounded corners, pressed from a single sheet.
- Internal and external doors, front and side panels and removable worktop in AISI 304 Stainless steel.
- External back panel in galvanized steel.
- Worktop in AISI 304 Stainless steel with a 50 mm profile.
- Built-in refrigeration unit.
- External bottom panel in stainless steel.
- Anti-drip profile on stainless steel worktop edge.
- 2 compartments with 2 doors.
- If needed, working top can be removed for easier handling during installation (in case of narrow doors).
- Ease of cleaning and high hygiene standards thanks to the rounded internal corners, the easily removable runners, grids and air conveyors.
- Internal structure with 15 charging positions (3 cm pitch) available to host GN 1/1 grids, ensuring higher net capacity and a greater storage space.

Sustainability



- R290 refrigerant to reduce green house and ozone depletion effects.
- Removable triple-chamber balloon magnetic gasket to improve insulation and reduce energy consumption and ease of cleaning
- CFC and HCFC free, highly ecological refrigerant type: R290 (ecological gas in foam: cyclopentane). Hydrocarbon refrigerant gas R290 for the lowest environmental impact (GWP=3), to reduce green house and ozone depletion effects.
- Extra insulation: 90mm body insulation to minimize energy dispersion.
- Fitted with 90 mm thickness of cyclopentane insulation for best insulating performance (thermal conductivity: 0,020 W/m*K) and lowest environmental impact (GWP=3).

Included Accessories

- 2 of Kit 1/1 grey rilsan grid and 2 side runners for refrigerated counters PNC 881109

Optional Accessories

- 1/1GN grey rilsan grid for refrigerated counters PNC 881107
- 2 side runners for 1/1 GN ecostore refrigerated counters PNC 881108
- Kit 1/1 grey rilsan grid and 2 side runners for refrigerated counters PNC 881109
- 1/1 GN plastic container, H=65 mm PNC 881110
- 1/1 GN plastic container, H=100 mm PNC 881111
- 1/1 GN plastic container, H=150 mm PNC 881112
- - NOT TRANSLATED - PNC 881242

Front

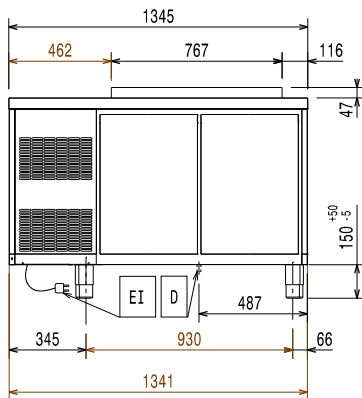

Side

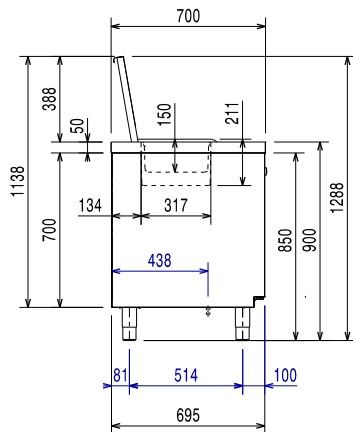

EI = Electrical inlet (power)

Top

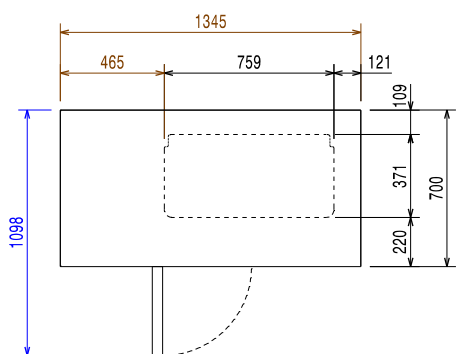
Electric

Supply voltage:	712691 (EHR2BLS)	220-240 V/1 ph/50 Hz
Electrical power max.:		0.25 kW
Defrost Power:		0.29 kW
Plug type:		UK-13A

Key Information:

Gross capacity:		198 lt
Net Volume:		1 Left+1 Right
Door hinges:		1 Left+1 Right
External dimensions, Width:		1345 mm
External dimensions, Depth:		700 mm
External dimensions, Height:		905 mm
Internal Dimensions, Width:		798 mm
Internal Dimensions, Depth:		560 mm
Internal Dimensions, Height:		550 mm
Net weight:		112 kg
Shipping volume:		1.14 m ³
Depth with doors open:		1110 mm
Height adjustment:		-5/50 mm

Refrigeration Data

Control type:	Digital
Compressor power:	1/4 hp
Refrigeration power at evaporation temperature:	-10 °C
Min/Max internal humidity:	40/85
Operating temperature min.:	-2 °C
Operating temperature max.:	10 °C
Operating mode:	Ventilated
Insulation:	90 mm (Cyclopentane)

ISO Certificates

ISO Standards:	ISO 9001; ISO 14001; ISO 45001; ISO 50001
----------------	---

Sustainability

Current consumption:	1.8 Amps
Energy Class (EU Reg. 2015/1094):	
Yearly and daily energy consumption (EU Reg. 2015/1094):	
Climate class (EU Reg. 2015/1094):	
Energy Efficiency Index-EEI (EU Reg. 2015/1094):	
Refrigerant type:	R290
GWP Index:	3
Refrigeration power:	320 W
Refrigerant weight:	70 g